



SOLARMAX

PRODUCT SPECIFICATIONS

A HIGH QUALITY CANTILEVER UMBRELLA THAT IS NOT ONLY EASY TO USE BUT WILL CREATE A SENSE OF SOPHISTICATION TO YOUR BACKYARD FOR MANY YEARS TO COME

FEATURES

- Infinite Tilt Positions – horizontal to 70°
- 360° umbrella rotation
- Detachable crank lever
- O'Bravia fabric
- Permanent base options
- Wind rated to 60km/h*

FOR FURTHER INFORMATION CONTACT US



Shade Australia Pty Ltd

A: 91 Stanley Road Ingleburn NSW 2565

E: info@shadeaustralia.com.au

P: 1800 155 233 or 02 9605 5560

W: shadeaustralia.com.au



SOLARMAX

PRODUCT SPECIFICATIONS



Shelta has really been clever in designing this brilliant new upmarket cantilever umbrella. It is beautifully crafted umbrella with an easy to use opening and closing mechanism and an almost automatic gliding tilt system. With infinite tilt positions and a 360° umbrella rotation to follow the sun all hours of the day.

FABRIC

High quality O'Bravia Canvas. Highly water resistant. UPF 50+. 3 year fade resistant warranty UPF 50+

FRAME

Powder coated Aluminium frame engineered to achieve 60kph wind rating.*

WARRANTY

1 year manufactures warranty on the frame.

INSTALLATION OPTIONS

Choose between on concrete bolt down base or the optional inground base. Due to its heavy construction the Asta is not suitable for a movable base option.

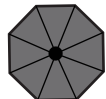

OCTAGONAL
4.0m



SQUARE
3.5m



RECTANGLE
3.0 x 4.0m

	OCTAGONAL 4.0m	SQUARE 3.5m	RECTANGLE 3.0 x 4.0m	
Area (m ²)	12.2 m ²	12.25m ²	12m ²	
Mast	Oval 120 x 76 mm			
Frame	Shadow Silver / Anthracite Powder coated			
Opening	Detachable Winder System			
Tilt	Variable to 55°			
Dimensions (mm)	A	4000	3500	3000 x 4000
	B	2820	2820	2820
	C	2110	2190	2190

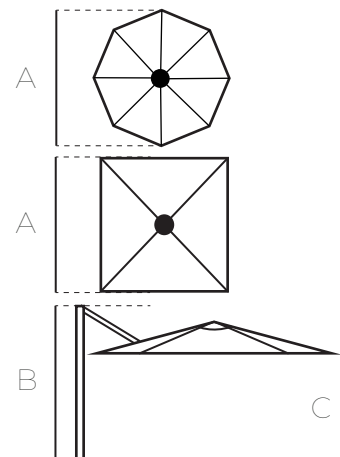

CANOPY COLOURS



Natural



Boulder



Black



Charcoal Ridge

*Wind ratings have tested under university controlled conditions. We recommend closing this umbrella in windy conditions. Wind damage is not covered by warranty.