



SUNHAVENTM
PREMIUM CANTILEVER UMBRELLA

USER INFORMATION



Sunranger[®]
Umbrellas
The hotter it gets, the harder they work[™]

Proudly distributed in Australia by
Shade Australia Pty Ltd

shadeaustralia.com.au

Congratulations on the purchase of a new Sunhaven Cantilever Umbrella. With proper care, your new umbrella will provide many years of reliable service.

Important Operational Notes

Although this umbrella can withstand some wind, we recommend that in breezy conditions it be collapsed, secured and covered.

If you have the umbrella is in a tilt position it will catch more wind than if it is in the horizontal position. Do not tilt the umbrella in breezy conditions.

Never leave the umbrella unattended. Sudden gusts could cause damage or injury if the umbrella is blown over.

The movable base options are not as secure as the bolt-down or inground options. Exercise extra care if the umbrella is on a movable base if it is breezy.

Please note: The warranty for this umbrella is for workmanship only. It does not cover damage caused by wind. Please exercise caution at all times.

General Care & Safety Warnings

- Keep hands and fingers clear of the umbrella frame when opening or closing the frame.
- Do not allow young children to operate the umbrella.
- Supervise young children when they are around the umbrella.
- Do not use in windy conditions.
- Never force the handle or any part of the umbrella.
- Do regular checks to ensure no parts have come loose or are damaged. Check all bolts are tight, that nothing is twisted or loose. If you notice something irregular, do not use umbrella. Contact the supplier.
- Do not leave the umbrella unattended whilst opened. Sudden gusts of wind can occur which could cause damage or injury. Always close the umbrella and secure with strap and cover.
- If the fabric becomes marked from birds or other environmental elements, use warm soapy water and sponge clean.
- If installed near a saltwater pool or near the ocean, regular wiping down of the frame is recommended. A light spray of WD40 or the like on the footpedal rotation mechanism is recommended to prevent it becoming stiff.
- If you are forced to collapse the umbrella when it is wet, wait until conditions improve and open the umbrella to air-dry. Putting the umbrella down and covering for extended periods while wet can cause mould or mildew on the fabric. This is not covered by warranty.

Clearances

3.5m Octagonal

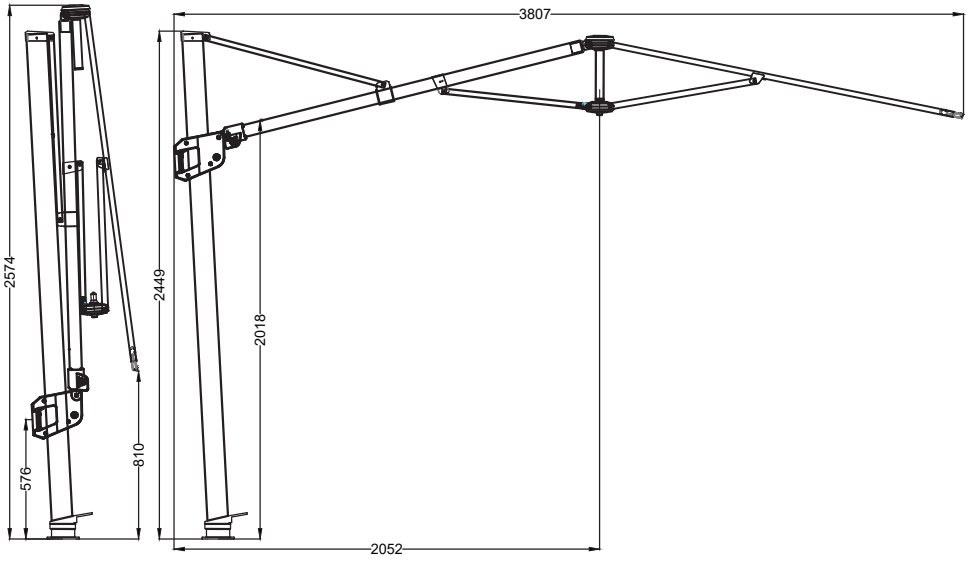

3.0m Square

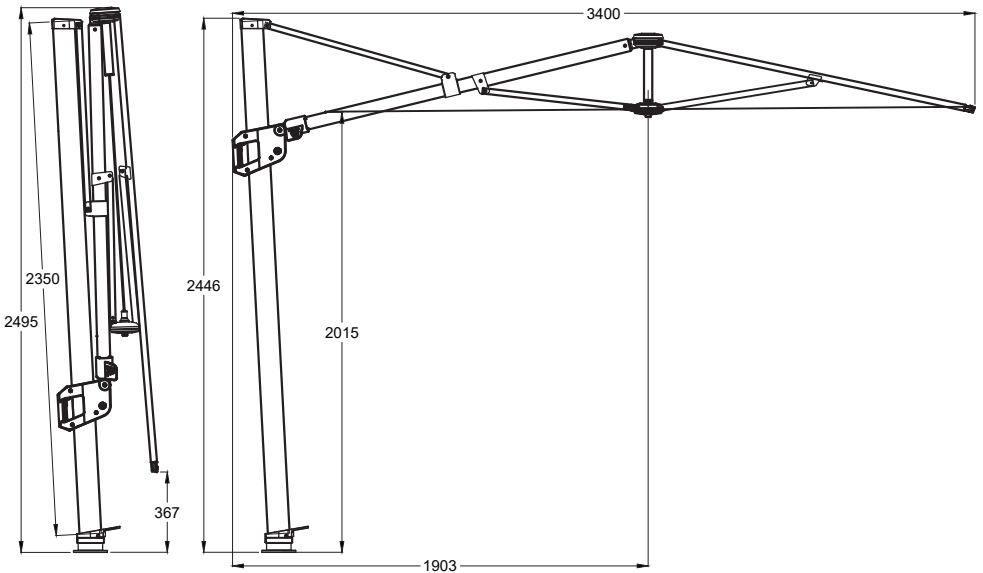

Components

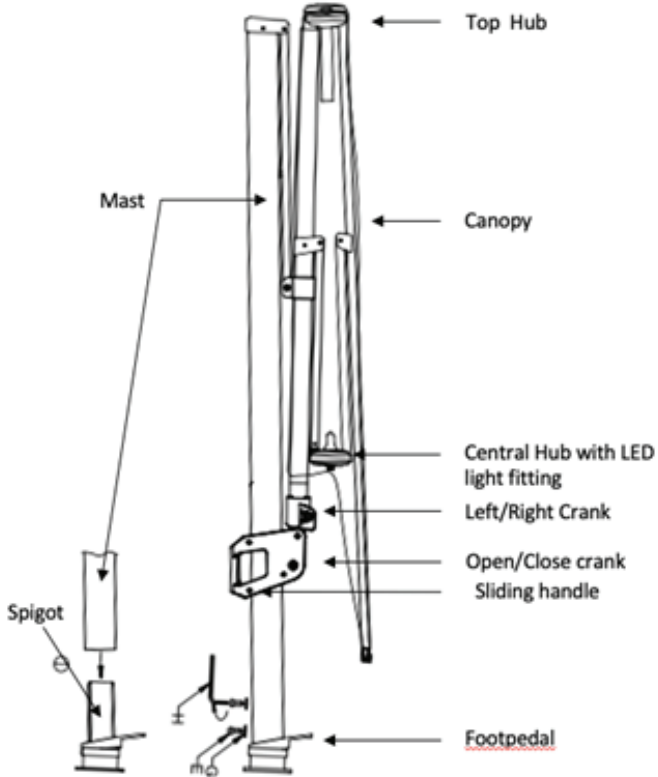

	Pic	Parts	Qty
A			1
B			1
C		M10*20	4
D		∅10	4
E		8#	4
F		M8*16	2
G		∅8	2
H		6MM	1
I			1

Warranty

Shade Australia warrants this umbrella frame to be free of manufacturing faults and defects to the original purchaser from the original date of purchase for a period of one year. Warranty is extended to manufacturing faults and defects only. The canopy fabric is warranted for 4 years pro-rata against fading. Warranty only covers normal use in a domestic setting by the original purchaser.

Warranty does not cover any of the following;

- Damage caused by incorrect installation or assembly.
- Damage caused by wind
- Damage caused by external events such as tree branches
- Warranty is voided if any alterations or unauthorised repairs are made to the umbrella
- Normal wear and tear
- Use in a commercial application. (This umbrella is sold for domestic usage only)
- Warranty is only extended to the original purchaser. Proof of purchase will be required to execute a warranty claim
- Natural events such as rain, wind, flood or fire
- Lack of routine maintenance will void warranty (e.g., if bolts are not regularly retightened)

Consumer Guarantees

• Our goods come with guarantees that cannot be excluded under Australian Consumer Law. You are entitled to a replacement or refund for a major failure and compensation for any other reasonably foreseeable loss or damage. You are also entitled to have the goods repaired or replaced if the goods fail to be of acceptable quality and the failure does not amount to a major failure. Such guarantees may include the right to a remedy from Shade Australia if our products are not of an acceptable quality or do not match any demonstration model or sample (as those terms are defined in the Competition and Consumer Act (CCA)).

Shade Australia reserves the right to assess any warranty claims before honouring. The umbrella will need to be returned to Shade Australia or a nominated place for assessment. It is the responsibility of the customer to get the goods to the place of assessment. Once assessed, the customer will receive a written notification of the outcome. If the claim is deemed valid, the umbrella will be repaired or replaced and returned to the customer at Shade Australia's cost.

Shade Australia cannot and will not be liable for any act, default, omission, or representation made by any person other than our employees, alterations made to

the product not performed by us, damage, or defects due to unusual or non-recommended use, or damage or loss caused by any factors beyond our control. Shade Australia's total liability in respect of a claim by a consumer under the Competition and Consumer Act (CCA) for a minor problem (as defined in the CCA) with a product is limited, at our option to, providing the consumer with a repair, replacement, or refund.

Subject to the above paragraphs, all express or implied representations, conditions, statutory guarantees, warranties, and provisions (whether based on statute, common law or otherwise), relating to this warranty, that are not contained in it, are excluded to the fullest extent permitted by law.

Nothing in this warranty excludes, restricts, or modifies any condition, warranty, statutory guarantee, right or remedy, implied or imposed by common law, statute, or regulation, which cannot be lawfully excluded, restricted, or modified.

Base Installation

Before you can install the umbrella, you must correctly set-up/install the base. The Sunhaven is suited to a number of base options. The umbrella must be installed correctly on one of the bases before operating. The ideal location for the base is towards the northern side of where you want the shade to cast.

Cross Bar base

- Lay the two bars on the ground in an X pattern.
- Using the Allen-key provided screw the Foot-pedal onto base with the 4 bolts provided.
- Use 8 x 450mm sq. pavers (double stacked) as ballast.

Bolt Down Baseplate

- Use 4 x Hilti M8 anchors, Dyna-bolts or equivalent to bolt the base to a suitable concrete slab. Slab should be at least 100mm thick and reinforced.
- Using the Allen-key provided screw the Foot-pedal onto base with the 4 bolts provided.

Sand Water Base

- Remove the top resin cover. The frame contains 4 plastic tubs.
- Fill each of the tubs. The best mix is to fill with sand to the top and top up with water.
- If you are using castors, fit the castors onto the frame before re-fitting the tubs.
- Place the tubs back into the frame and replace the lid.
- Using the Allen-key provided screw the Foot-pedal onto base with the 4 bolts provided.

Ballast Block Frame

- The Ballast Block Frame is designed to accept 8 x 450mm pavers.
- If you are using castors, fit the castors onto the frame before fitting the pavers.
- Carefully stack these into the frame – double stack.
- Using the Allen-key provided screw the Foot-pedal onto base with the 4 bolts provided

Inground Base

- Dig hole to size indicated – approx. 60cm deep x 40cm dia. (assumes firm natural ground - if loose or sandy soil, footing should be bigger). Fill with concrete (20mpa) mix. Screw bolts into threads (to prevent concrete getting into threads).
- Push inground base into concrete. Base must be perfectly level. Use a spirit level on top plate to check.
- It is very important to ensure the spigot is completely vertical. Leave until concrete is set before installing the umbrella.
- Remove bolts.
- Using the Allen-key provided to screw the Foot-pedal onto base with the 4 bolts provided

Umbrella Installation

Now that you have the base installed/set-up you are ready to install the umbrella.

- Two people should remove the umbrella from the packaging.
- The umbrella should be slid over the foot-pedal spigot which has been bolted to the base.
- Secure the umbrella frame to the spigot with the 2 bolts that go through the mast at the back into the base spigot.
- Remove all cardboard and other packaging materials. Packaging may have been fitted to the umbrella underneath the canopy skirt.

Operation

To open the umbrella, remove the protection cover and undo the Velcro strap. It helps if you push the canopy outwards away from the umbrella slightly to get started. Do not force anything!

With one hand on the crank handle and the other on the Sliding handle, squeeze the trigger and wind the crank handle clockwise and lift all at the same time. The idea is to keep the canopy approximately parallel to the ground.

Continue until the umbrella is fully opened and taut. Now you can tilt the umbrella up and down the mast as required. Grasp the sliding handle, squeeze the trigger and raise, lower handle accordingly to tilt.

If you wish to tilt the umbrella side to side, remove the crank handle from its slot and

SUNHAVEN™

place it in the second slot. By winding, you are able to tilt the umbrella whereby the left hand side lowers as the right hand side raises up and vice versa. To rotate the entire umbrella, push the foot-pedal and turn the umbrella. Once you release the foot-pedal it will automatically lock into place.

Wind stabiliser straps can be a good option for this umbrella. They attach to the frame and onto the outer arms giving the umbrella additional stability from lateral winds. They are not designed to make the umbrella into a windproof umbrella, they merely add some extra stability in breezy conditions.

To close the umbrella, use the sliding handle so it is back in the horizontal position. Place crank handle in first slot and wind anti-clockwise. At the same time grasp sliding handle and lower. When umbrella is fully closed, secure with Velcro strap and fit protection cover.

FOR FURTHER INFORMATION CONTACT US



Shade Australia Pty Ltd

A: 91 Stanley Road Ingleburn NSW 2565

E: info@shadeaustralia.com.au

P: 1800 155 233 or 02 9605 5560

W: shadeaustralia.com.au
